

# Amber Instruments Ltd

## Shear Beam Load Cell



### FEATURES

- Capacities 250-2000kg and 1000-4000lbs
- Steel and stainless steel construction
- OIML R60 and NTEP approved
- IP67 protection

### OPTIONAL FEATURES

- EEx ia IIC T6 hazardous area approval
- FM approval available

### DESCRIPTION

Model SB41 is a low profile shear beam load cell designed for high accuracy platform scales, pallet scales and process weighing applications.

It has high immunity to shock or side loading and is available in 2 or 3mV/V sensitivity. Approved to OIML, NTEP standards. For hazardous environments this load cell is available with EEx ia IIC T6 level of European approval.

Nickel plating and full environmental sealing assures long term reliability. A stainless steel option is available for the lb versions for use in harsh or corrosive environments.

The two additional sense wires feed back the voltage reaching the load cell. Complete compensation of changes in lead resistance due to temperature change and/or cable extension is achieved by feeding this voltage into the appropriate electronics.

### APPLICATIONS

- Low profile platforms
- Pallet truck weighing
- Tank and silo weighing

### OUTLINE DIMENSIONS in millimeters

Outline Dimensions All Capacities in mm

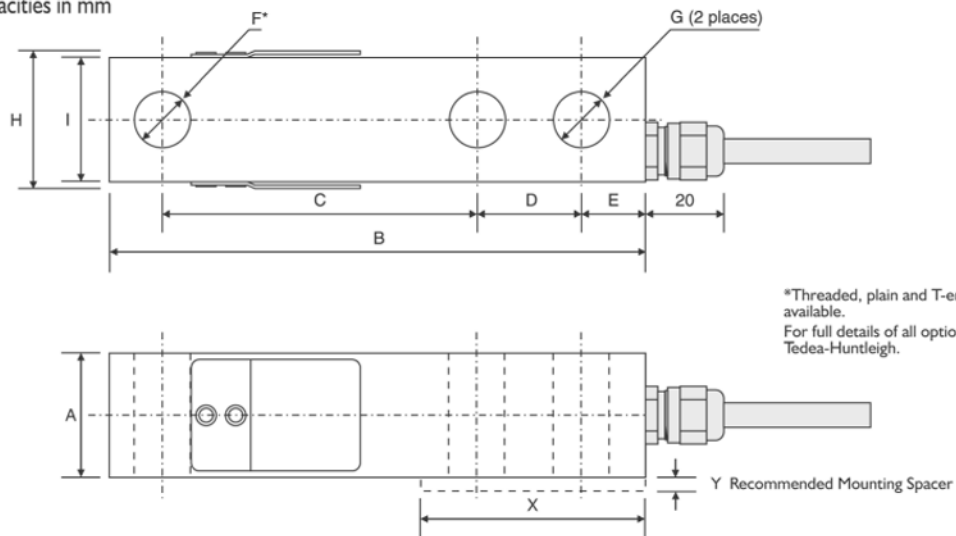

\*Threaded, plain and T-end options are available.  
For full details of all options contact Tedeo-Huntleigh.

CAPACITY	A	B	C	D	E	ØF	ØG	H	I	X	Y
1000, 1500, 2500, 4000lb.	30.5	130	76.2	25.4	16	Ø13.5	Ø13.5	34.0	30.5	57	4
250, 500, 1000 kg.	30.5	130	76.2	25.4	16	M12*	Ø13.5	34.0	30.5	57	4
2000 kg.	36	130	76.2	25.4	16	M12*	Ø13.5	34.0	30.5	57	4

\* Tapped M12 X 1.75 & counterbored Ø13.5 X 14.5 Deep

## SPECIFICATIONS

PARAMETER	VALUE			UNITS
	NTEP	Non Approved	C3	
NTEP/OIML Accuracy class				
Maximum no. of intervals (n)	3000 single 5000 multiple	1000	3000*	
Rated capacity-R.C. ( $E_{max}$ )	250, 500, 1000, 2000			kg
Rated output-R.O.	2.0			mV/V
Rated capacity-R.C. ( $E_{max}$ )	1000, 1500, 2500, 4000			Lbs.
Rated output-R.O.	3.0			mV/V
Rated output tolerance	0.1			± % of rated output
Zero balance	2			± % of rated output
Zero Return, 30 min.	0.0250	0.0300	0.0170	± % of applied load
Total Error (per OIML R60)	0.0200	0.0500	0.0200	± % of rated output
Temperature effect on zero	0.0023	0.0100	0.0023	± % of rated output/°C
$Y = E_{max}/V_{min}$	6666	1400	10000	
Temperature effect on output	0.0010	0.0300	0.0010	± % of applied load/°C
Temp. range, compensated	-10 to +40			°C
Temp. range, safe	-20 to +70			°C
Maximum safe central overload	150			% of R.C.
Ultimate central overload	300			% of R.C.
Excitation, recommended	10			Vdc or Vac rms
Excitation, maximum	15			Vdc or Vac rms
Input impedance	385 ± 10			Ohms
Output impedance	351 ± 5			Ohms
Insulation resistance	> 2000			Mega-Ohms
Cable length	3410-3.0, 3411-6.0			m
Cable type	6 wire, braided, Polyurethane, floating screen			Standard
Construction	Nickel plated alloy steel and stainless steel			
Environmental protection	IP67			
Recommended torque	136			N*m

\* 50% utilization

Wiring Schematic Diagram

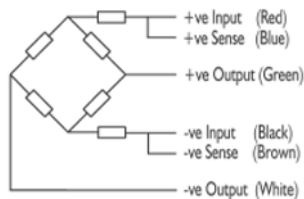

# Amber Instruments Ltd

Tel: +44 (0)1246 260250 | E-mail: [sales@amberinstruments.com](mailto:sales@amberinstruments.com)  
 Web: [amberinstruments.com](http://amberinstruments.com)  
 3 Mercury House, Calleva Park, Aldermaston, Berkshire, RG7 8PN.