



Stainless Steel Shear Beam Load Cell



FEATURES

- Capacities 300-5000 kg, 1000-5000 lbs
- Stainless steel construction
- OIML R60 and NTEP approved
- Hermetically sealed to IP68
- Specially designed for harsh environment

OPTIONAL FEATURES

- EEx ia IIC T6 hazardous area approval
- FM approval available

DESCRIPTION

Model SB51 provides the weighing industry with the ultimate protection necessary for today's hostile environments in an economical low profile range suitable for platform scale manufacture.

Its low profile and all welded sealing combined with high accuracy makes this load cell ideally suited for low profile platforms, pallet truck weighers, tanks and silos. The guide slots incorporated into the upper and lower mounting faces enable manufacturers to easily position the load cell.

Hermetically sealed against moisture, the construction of the model SB51 in combination with a polyurethane dual shielded cable, enables continuous operation in harsh environments while maintaining a high operating specification.

The two additional sense wires feed back the voltage reaching the load cell. Complete compensation of changes in lead resistance due to temperature change and/or cable extension, is achieved by feeding this voltage into the appropriate electronics.

APPLICATIONS

- Low profile platforms
- Pallet truck weighing
- Tank and silo weighing
- Harsh environment weighing
- Food industry weighing

OUTLINE DIMENSIONS in millimeters

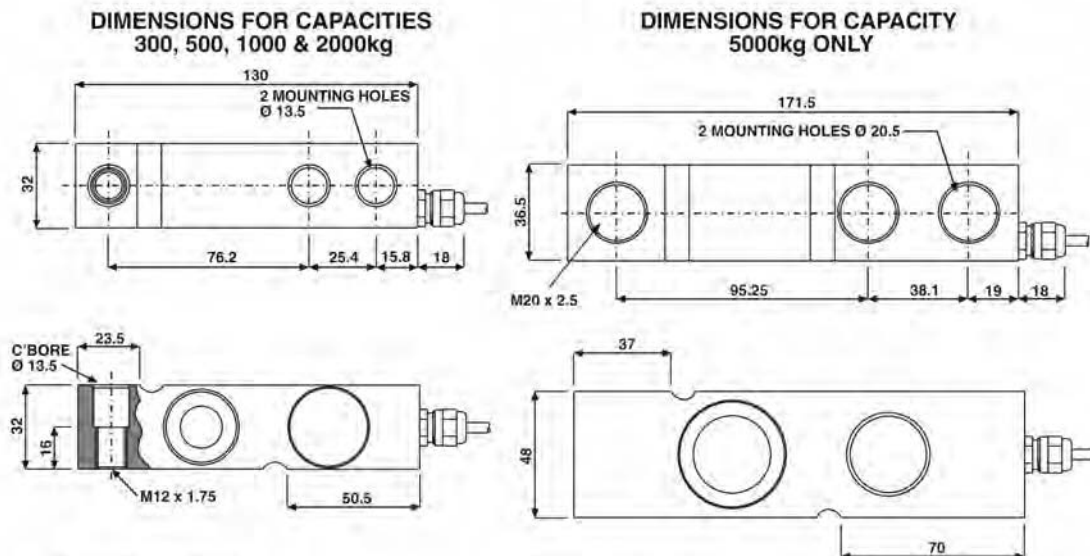

Standard end loading shown.
Options include:
• 'Through-hole' - plain or threaded.
• 'T-End' - supplied current and voltage matched for platforms.

SPECIFICATIONS

PARAMETER	VALUE				UNIT
	NTEP	Non-Approved	C3	C6	
NTEP/OIML Accuracy class					
Maximum no. of intervals (n)	3000 single 5000 multiple	1000	3000*	6000**	
$Y = E_{max}/V_{min}$	12500	4000	12000	15000	Maximum available
Rated capacity-R.C. (E_{max})	300, 500, 750, 1000, 1200, 2000, 3000, 5000				kg
Rated output-R.O.	2.0				mV/V
Rated capacity-R.C. (E_{max})	1000, 1500, 2500, 4000, 5000				lbs
Rated output-R.O.	3.0				mV/V
Rated output tolerance	0.1				± % of rated output
Zero balance	2				± % of rated output
Zero Return, 30 min.	0.0250	0.0300	0.0170	0.0083	± % of applied load
Total Error	0.0200	0.0500	0.0200	0.0100	± % of rated output
Temperature effect on zero	0.0023	0.0100	0.0023	0.0014	± % of rated output/°C
Temperature effect on output	0.0010	0.0300	0.0010	0.00058	± % of applied load/°C
Temp. range, compensated	-10 to +40				°C
Temp. range, safe	-20 to +70				°C
Maximum safe central overload	150				% of R.C.
Ultimate central overload	300				% of R.C.
Excitation, recommended	10				Vdc or Vac rms
Excitation, maximum	15				Vdc or Vac rms
Input impedance	415 ± 15				Ohms
Output impedance	350 ± 3				Ohms
Insulation resistance	> 2000				Mega-Ohms
Cable length	5				m
Cable type	6 wire, braided, Polyurethane, dual floating screen				Standard
Construction	Stainless steel				
Environmental protection	IP68				
Recommended torque	All capacities up to 5000 kg - 136.0 5000 kg - 205.0				N*m

* 50% utilization

** Capacities 300-1200 kg, and 1000-2500 lbs only

Wiring schematic diagram

