



Low Capacity Shaft Driven Transformer Coupled Torque Sensor Model T260



T260 Rotary Transformer Torque Sensor with i200 AC Carrier Strain Gage Signal Conditioning Electronics

- *Non-contact measurement of torque*
- *High stiffness and low inertia*
- *On-board shunt calibration circuit*
- *Rated speed 20,000 rpm (35,000 rpm optional)*
- *Internal zero velocity speed sensor (optional)*
- *SAE 4340 alloy steel construction with satin nickel finish*

The T260 rotary transformer coupled torque sensor was designed for the measurement of viscosity and for in-line testing of motors, engines, transmissions, propellers, pumps, drivelines, and similar rotating devices. The T260 has 20% to 40% greater stiffness, has 4 to 6 times less rotating inertia, and is 1/3 the size of comparable models available from other suppliers. The T260 requires the use of AC carrier strain gage signal conditioning electronics such as SensorData's i200. The optional zero velocity speed sensor is installed inside the T260 housing. Interconnecting cable assemblies are available as an option. SensorData will provide in-house calibration of the T260 with customer-supplied electronics for a fee.

Specifications

(Subject to change without notice)

| | |
|--|---|
| Rated Capacity | 100, 200, 500, 1K, 2K lb-in |
| Rated Speed | 20,000 rpm (35,000 rpm optional) |
| Nonlinearity | 0.05% of rated output |
| Hysteresis | 0.05% of rated output |
| Nonrepeatability | 0.02% of rated output |
| Rated Output, bridge, typical | 2 mV/V |
| Zero Balance | +/-0.5% of rated output |
| Temperature Range, operating | -20 to +200 F |
| Temperature Range, compensated | +68 to +170 F |
| Temperature Effect on Output | 0.001% of load/F |
| Temperature Effect on Zero | 0.001% of rated output/F |
| Bridge Resistance, typical | 350 ohms |
| Excitation | 2.8 to 5 VAC rms, 3 kHz to 5 kHz |
| Insulation Resistance, bridge to case | >5000 megohms at 50 VDC |
| Input voltage, speed sensor, V _{cc} (optional) ⁽¹⁾ | 4.5 to 24 VDC |
| Maximum Load, safe ⁽²⁾ | 200% of rated capacity |
| Maximum Load, ultimate ⁽³⁾ | 400% of rated capacity |
| Number of Bridges | 1 |
| Weight | 4 lb without i200, 5 lb with i200 |
| Construction | SAE 4340 alloy steel with satin nickel finish |

⁽¹⁾ Output is an open collector NPN with internal 4.7K ohm pull up resistor

⁽²⁾ With load centered, maximum torque that can be applied without producing a permanent shift in performance characteristics.

⁽³⁾ With load centered, maximum torque that can be applied without physical damage.

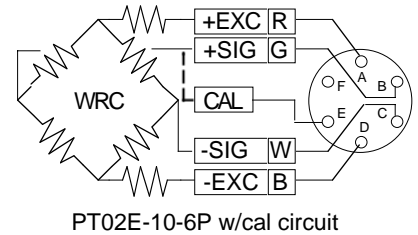
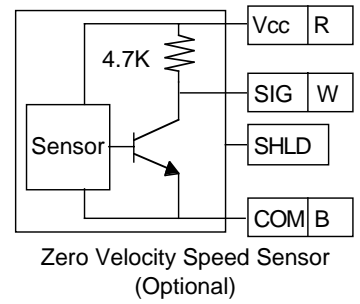
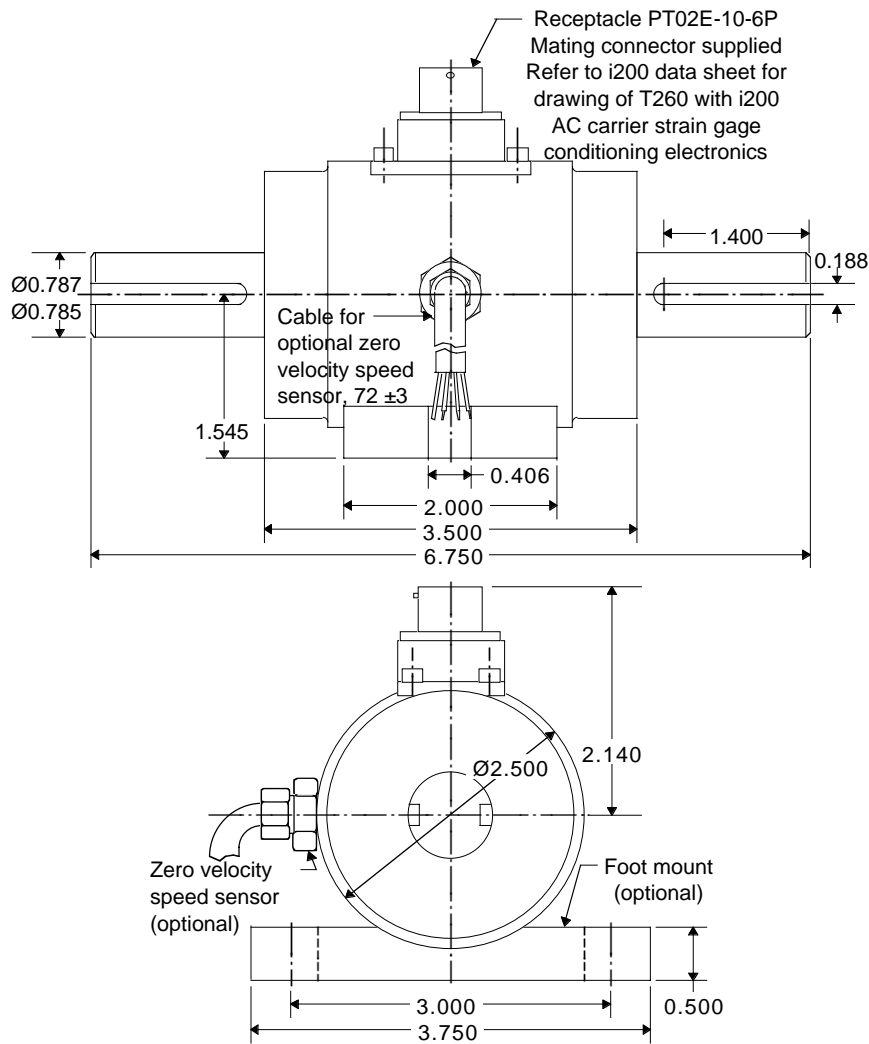

| Capacity lb-in | Torsional Stiffness lb-in/rad | Rotating Inertia lb-in-sec ² |
|-------------------|-------------------------------------|---|
| 100 | 34 x 10 ⁻³ | 6.6 x 10 ⁻⁴ |
| 200 | 39 x 10 ⁻³ | 6.6 x 10 ⁻⁴ |
| 500 | 54 x 10 ⁻³ | 6.6 x 10 ⁻⁴ |
| 1K | 85 x 10 ⁻³ | 6.6 x 10 ⁻⁴ |
| 2K | 95 x 10 ⁻³ | 6.6 x 10 ⁻⁴ |

NOTE

If the T260 is supplied with the optional SensorData i200 AC carrier strain gage conditioning electronics, the i200 instruction manual or data sheet should be referred to for wiring information and specifications.

ORDERING INFORMATION

- T260-STD-Capacity Standard with receptacle and mating connector.
- T260-STD-Capacity-A Same as T260-STD-Capacity except supplied with SensorData i200 strain gage conditioning electronics.
- T260-STD-Capacity-S Same as T260-STD-Capacity except supplied with zero velocity speed sensor.
- T260-STD-Capacity-S-A Same as T260-STD-Capacity except with zero velocity speed sensor & i200 strain gage conditioning electronics.
- Foot Mount Option Replace STD with 105 in above model designations; e.g., T260-105-Capacity-S-A
- 35,000 RPM Option Replace STD with 111 in above model designations; e.g., T260-111-Capacity-S-A. Not available with foot mount.
- Cable Assembly Optional; 10 ft., color coded, shielded, mating connector sensor end, customer specified connector instrument end.
- Cable Assembly Optional; 10 ft., color coded, shielded, mating connector sensor end, leads stripped and tinned instrument end.
- Note Mounting hardware is optional and not included unless specified at time of order

IMPORTANT NOTICE

Dimensions above are in inches unless otherwise noted. Manufacturer not responsible for any modification to product, fixtures, or accessories made by user or third party. User should request certified drawings before designing mountings or fixtures. Manufacturer reserves right to modify or change design, dimensions, specifications, and features of this product without prior written notice. Changes to NOTICE must be in writing and accepted by manufacturer.