

Amber Instruments Ltd

Tel: +44 (0)1246 260250 | E-mail: sales@amberinstruments.com
Web: amberinstruments.com
3 Mercury House, Calleva Park, Aldermaston, Berkshire, RG7 8PN.

Small Capacity Shaft Driven Slip ring Torque Sensor Model T331



- 5" overall length including shafts
- 1 1/2" square housing
- Weighs less than 1 lb.
- Zero velocity speed sensor (optional)
- SAE 4340 alloy steel - satin nickel finish
- Supplied with mating connector

T331-105-200 with standard foot mount

The T331 is designed for in-line testing of small motors, pumps, compressors, turbines, fans, and other fractional horsepower rated devices. The slip ring allows the use of either AC carrier or DC strain gage signal conditioning electronics. The T331 is supplied with a foot mount as standard. The optional zero velocity speed sensor is installed inside the T331 housing. Interconnecting cable assemblies are available as an option. In-house calibration of the T331 with SensorData electronics will be provided free of charge or with customer-supplied electronics for a fee.

Specifications

(Subject to change without notice)

Rated Capacity	50, 100, 200, 500, 1K, 1.2K oz-in
Rated Speed	20,000 rpm
Nonlinearity	0.10% of rated output
Hysteresis	0.10% of rated output
Nonrepeatability	0.05% of rated output
Rated Output, typical	1.5 mV/V
Zero Balance	+/-1% of rated output
Temperature Range, operating	-65 to +200 F
Temperature Range, compensated	+70 to +170 F
Temperature Effect on Output	0.002% of load/F
Temperature Effect on Zero	0.002% of rated output/F
Bridge Resistance, typical	350 ohms
Excitation Voltage, bridge, typical	10 VDC or VAC rms
Excitation Voltage, bridge, maximum ⁽¹⁾	20 VDC or VAC rms
Insulation Resistance, bridge to case	>5000 megohms at 50 VDC
Input voltage, speed sensor, V _{cc} (optional) ⁽²⁾	4.5 to 24 VDC
Maximum Load, safe ⁽³⁾	150% of rated capacity
Maximum Load, ultimate ⁽⁴⁾	300% of rated capacity
Deflection at Rated Capacity, typical	0.15 degrees of arc
Number of Bridges	1
Weight	0.75 lbs
Construction	SAE 4340 alloy steel with satin nickel finish

⁽¹⁾ Temperature gradients caused by higher excitation voltages may effect performance.

⁽²⁾ Output is an open collector NPN with internal 4.7K ohm pull up resistor.

⁽³⁾ With load centered, maximum torque that can be applied without producing a permanent shift in performance characteristics.

⁽⁴⁾ With load centered, maximum torque that can be applied without physical damage.

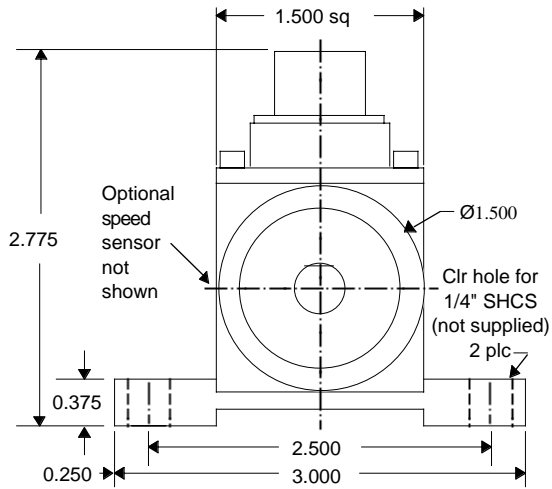

Capacity oz-in	Stiffness oz-in/rad	Inertia oz-in-sec ²
50	10.7×10^3	0.5×10^{-3}
100	21.3×10^3	34.2×10^{-3}
200	37.4×10^3	49.6×10^{-3}
500	173.9×10^3	50.9×10^{-3}
1K	347.8×10^3	76.5×10^{-3}
1.2K	417.4×10^3	96.6×10^{-3}

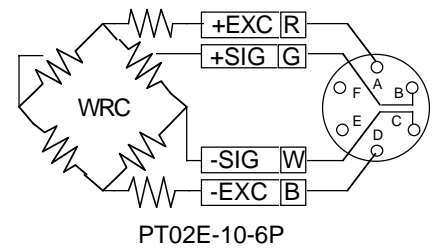
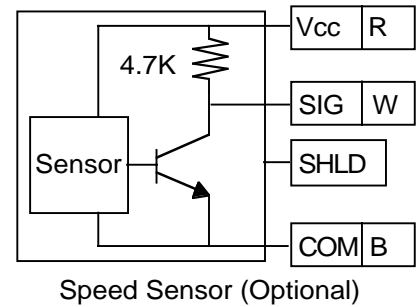
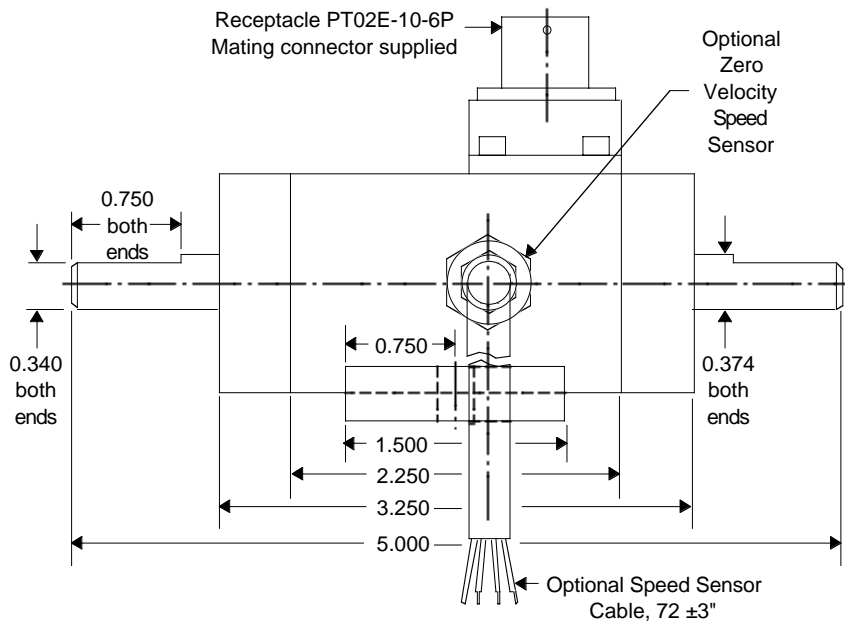

ORDERING INFORMATION

- T331-105-Capacity Standard; supplied with foot mount, receptacle and mating connector. Mounting hardware not included.
- T331-105-Capacity-S Standard with internal zero velocity speed sensor with integral 6ft. cable, leads stripped and tinned instrument end.
- Cable Assembly Optional; 10 ft., color coded, shielded, mating connector sensor end, customer specified connector instrument end.
- Cable Assembly Optional; 10 ft., color coded, shielded, mating connector sensor end, leads stripped and tinned instrument end.

IMPORTANT NOTICE

Dimensions above are in inches unless otherwise noted. Manufacturer not responsible for any modification to product, fixtures, or accessories made by user or third party. User should request certified drawings before designing mountings or fixtures. Manufacturer reserves right to modify or change design, dimensions, specifications, and features of this product without prior written notice. Changes to NOTICE must be in writing and accepted by manufacturer.