



## S-Type Stainless Steel Load Cell



### FEATURES

- Capacity range: 500 to 5000kg
- Stainless Steel construction
- sealed by welding to IP68
- S-Type design for use in tension and compression
- OIML approved to 3000d (500-5000kg)
- NTEP approved to 5000d (500-2000kg)
- Choice of mounting threads Metric or Unified systems.
- Six Wire Cable (sense circuit)

### OPTIONAL FEATURES

- EEx ia IIC T6-ATEX hazardous area approval.
- Class I, II, III Division 1 – FM hazardous area approval.

### DESCRIPTION

Model 620 is a Stainless Steel S-Type Load Cell. Its Welded Sealing combined with high accuracy, make this Load Cell ideally suited for a wide range of applications of Process Weighing and Force Measurements.

Approvals include OIML C3 (3000d); NTEP 3000d single and NTEP 5000d Multiple.

Also available are versions approved for hazardous areas – ATEX II 1 GD EEx ia T6

for Europe and FM I, II, III Division 1 for the USA.

The six-wire cable includes two sense wires that compensate for changes in lead resistance due to temperature changes and cable extension.

Model 620 offers a choice of bolt threads in Metric or Unified systems – see table below.

### APPLICATIONS

- Hopper (Tank Weighing).
- Hybrid Scales.
- Belt Weighing.
- Lever arm conversions.
- Material testing machines.
- Vibrations filling equipment.
- Dynamometers.

### OUTLINE DIMENSIONS in millimeters

Wiring Schematic Diagram

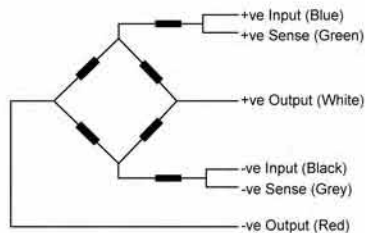

Thread Type "T" By Capacity		
Capacity	Metric	Unified
500 kg	M12x1.75	1/2-20 UNF
1000 kg	M16 x 2.0	1/2-20 UNF
2000 kg	M16 x 2.0	3/4-16 UNF
5000 kg	M24 x 2.0	1 - 12 UNF

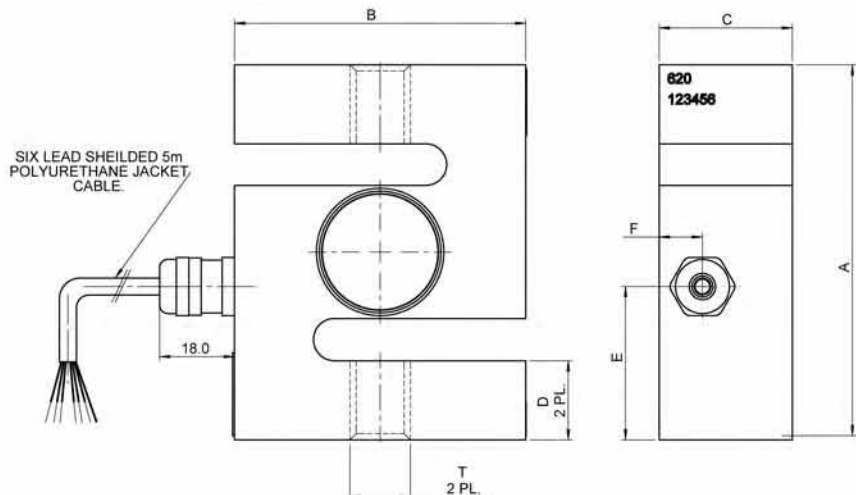

Capacity	A	B	C	D	E	F
500, 1000, 2000 kg	90	70	32	19	36.6	10.4
5000 kg	120	100	45	26	60	13.8

available – consult V.P. Sales Office

## SPECIFICATIONS

PARAMETER	VALUE			UNIT
Vishay T-H Accuracy Class	E	F5	G/G5	
OIML Accuracy class	non-approved	C2/50	C3/50	
NTEP Accuracy class	non-approved	III/2000 Single	III3000 Single III5000 Multiple	
Maximum number of intervals (n)	1000	2000	OIML 3000 NTEP 3000 Single NTEP 5000 Multiple	
Rated capacity-R.C (Emax)	500, 1000, 2000, 5000			kg
Rated output-R.O.	2.0			mV/V
Rated output tolerance	0.0035			± mV/V
Zero Balance	0.04			± mV/V
Zero Return, 30 min.	0.050	0.025	0.017	± % of load
Total error	0.050	0.030	0.020	± % of R.O.
Temperature effect on zero	0.0070	0.0020	0.0023	± % of R.O./°C
Y=Emax/Vmin	2000	4000	6000	
Temperature effect on output	0.040	0.0014	0.0012	± % of load/°C
Temperature range, compensated	-10 to +40			°C
Temperature range, safe	-30 to +90			°C
Maximum safe static overload	150			% of R.C.
Excitation, recommended	10			Vdc or Vac rms
Excitation, maximum	15			Vdc or Vac rms
Input Impedance	400±20			Ohm
Output Impedance	350±3			Ohm
Insulation resistance	>5000			MOhm
Cable length	5.0			m
Cable Type	6 conductors, 26 AWG, Shielded, Polyurethane jacket			
Construction	Stainless Steel, Sealed by Welding			
Environmental protection (DIN 40050)	IP 68			
Outline dimensions DWG.	251.000.00-03			

Note: NTEP Approval for capacities 500-2000 kg